

Please check the examination details below before entering your candidate information

Candidate surname

Other names

Centre Number

Candidate Number

Pearson Edexcel International Advanced Level

Thursday 30 October 2025

Afternoon (Time: 1 hour 20 minutes)

Paper
reference

WPH16/01

Physics

International Advanced Level

UNIT 6: Practical Skills in Physics II

You must have:

Scientific calculator, ruler

Total Marks

Instructions

- Use **black** ink or ball-point pen.
- If pencil is used for diagrams/sketches/graphs it must be dark (HB or B).
- **Fill in the boxes** at the top of this page with your name, centre number and candidate number.
- Answer **all** questions.
- Answer the questions in the spaces provided
– *there may be more space than you need.*
- **Show all your working out** in calculations and **include units** where appropriate.

Information

- The total mark for this paper is 50.
- The marks for **each** question are shown in brackets
– *use this as a guide as to how much time to spend on each question.*
- The list of data, formulae and relationships is printed at the end of this booklet.

Advice

- Read each question carefully before you start to answer it.
- Try to answer every question.
- Check your answers if you have time at the end.

Turn over ►

P79148A

©2025 Pearson Education Ltd.
M:1/1/1/



Pearson

Answer ALL questions.

- 1 A student investigated the oscillation of a trolley between two springs using the apparatus shown.

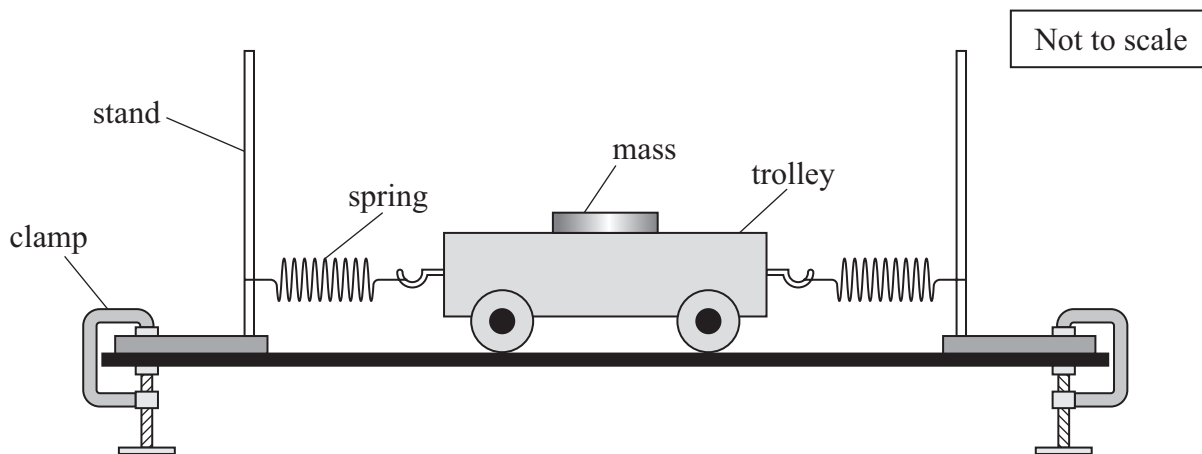

The student displaced the trolley towards a stand until one spring was compressed. She released the trolley so that it oscillated horizontally.

The student used a stopwatch to measure the time for multiple oscillations. She repeated the measurement and calculated a mean.

- (a) (i) Describe two techniques the student should use when timing these oscillations. (2)

.....

.....

.....

.....

- (ii) Explain how using a video camera could improve the results. (2)

.....

.....

.....

.....

DO NOT WRITE IN THIS AREA

DO NOT WRITE IN THIS AREA

DO NOT WRITE IN THIS AREA



DO NOT WRITE IN THIS AREA

DO NOT WRITE IN THIS AREA

DO NOT WRITE IN THIS AREA

(b) The student recorded the following measurements.

$5T/s$	5.25	5.16	5.21	5.19
--------	------	------	------	------

(i) Calculate the mean time period T of the oscillations.

(2)

Mean $T =$

(ii) Determine the percentage uncertainty in the mean value of T .

(2)

Percentage uncertainty =

(c) The student investigated how T varied with the mass of the trolley.

She recorded the following data to draw a graph.

Mass	T/s
1.3	1.01
1.8	5.90
2.3	1.34

Criticise the recording of the data.

(2)

(Total for Question 1 = 10 marks)



P 7 9 1 4 8 A 0 3 2 4

DO NOT WRITE IN THIS AREA

DO NOT WRITE IN THIS AREA

DO NOT WRITE IN THIS AREA

BLANK PAGE



DO NOT WRITE IN THIS AREA

2 A student investigated a current-carrying coil, using the apparatus shown.

Not to scale

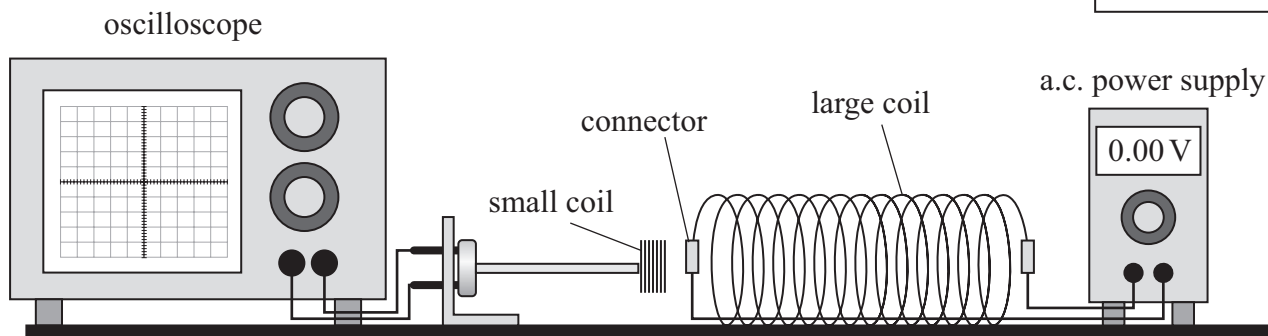

- (a) The student placed the small coil inside the large coil and switched on the a.c. power supply.

An e.m.f. was induced across the small coil. The induced e.m.f. was displayed on the oscilloscope screen, as shown below.

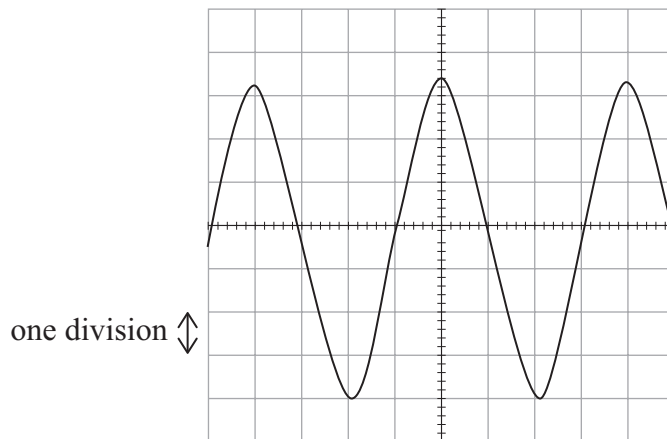

The vertical scale was set to 5 mV per division.

Determine the maximum e.m.f. induced across the small coil.

(3)

DO NOT WRITE IN THIS AREA

DO NOT WRITE IN THIS AREA

.....

.....

.....

.....

.....

Maximum e.m.f. induced =



(b) The connectors were a distance x apart, as shown below.

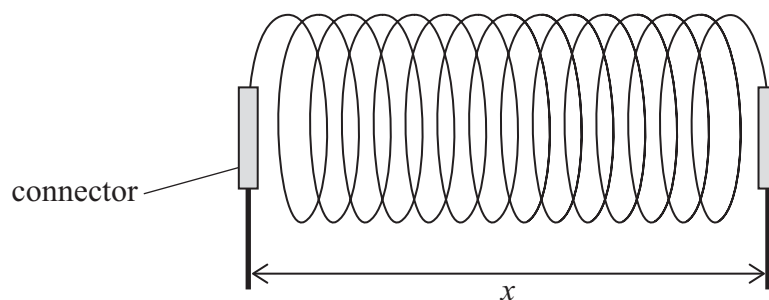

The relationship between the e.m.f. V induced across the small coil and the current I in the large coil is

$$V = \frac{zNI}{x}$$

where N is the number of turns in the large coil and z is a constant.

The student varied I to obtain results and plot a graph to determine a value for z .

(i) Complete the circuit diagram to show the circuit the student should use.

(2)

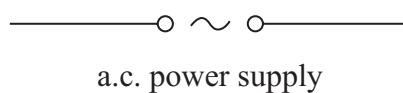
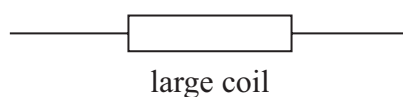

DO NOT WRITE IN THIS AREA

DO NOT WRITE IN THIS AREA

DO NOT WRITE IN THIS AREA

BLANK PAGE



- 3 A student investigated the discharge of a $680\ \mu\text{F}$ electrolytic capacitor. She connected the capacitor and a resistor with resistance R in a circuit, as shown.

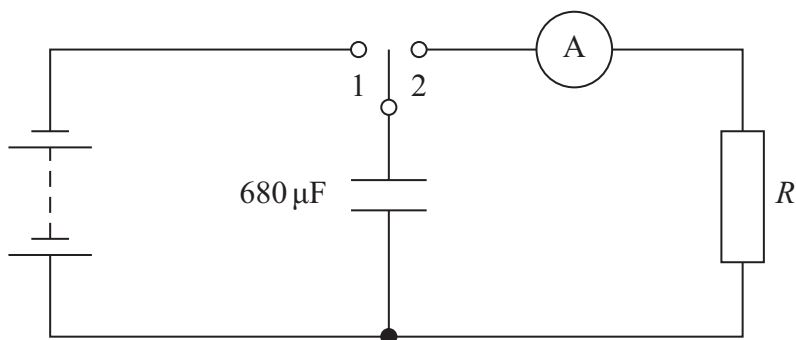

The student moved the switch to position 1 to charge the capacitor.

- (a) Describe two safety precautions the student should take when using an electrolytic capacitor in a circuit.

(2)

- (b) As the capacitor discharges, the current I is related to the time t by the expression

$$I = I_0 e^{-\frac{t}{RC}}$$

where I_0 is the current when $t = 0$.

- (i) Explain how a graph of $\ln I$ against t could be used to determine a value for R .

(2)



- (ii) The student moved the switch to position 2 and immediately started a stopwatch. She recorded I every 10 seconds.

The student recorded the following results.

t/s	I/mA	
10.00	0.237	
20.00	0.165	
30.00	0.105	
40.00	0.066	
50.00	0.043	
60.00	0.028	

Plot a graph of $\ln I$ against t on the grid opposite.

Use the additional column to record your processed data. You should keep the values of I in mA.

(5)

- (iii) Determine the value of R using the graph.

(4)

$R =$



DO NOT WRITE IN THIS AREA

DO NOT WRITE IN THIS AREA

DO NOT WRITE IN THIS AREA

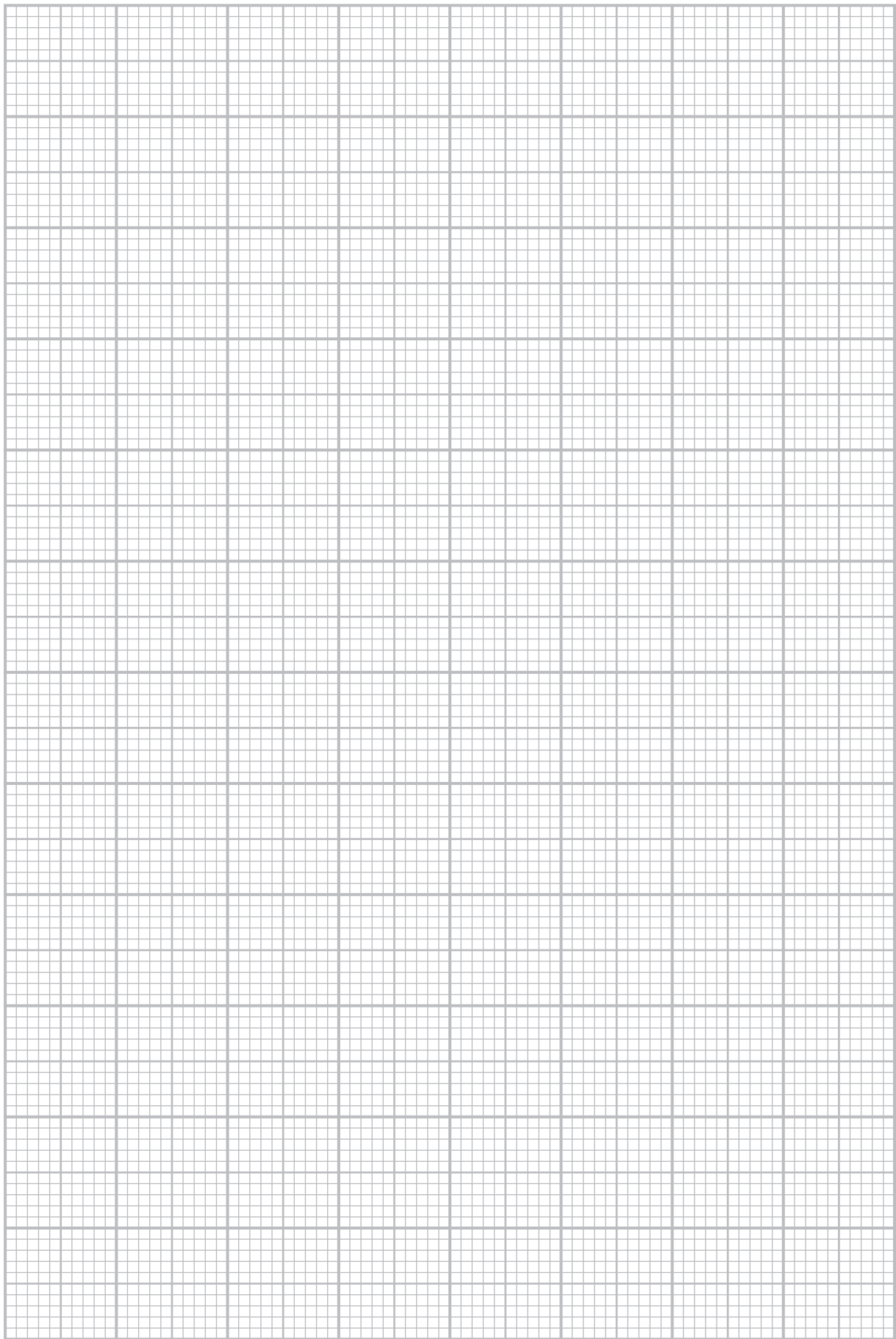

(c) Explain how using a data logger instead of using an ammeter and stopwatch would improve the investigation.

(2)

.....

.....

.....

.....

(Total for Question 3 = 15 marks)

DO NOT WRITE IN THIS AREA

DO NOT WRITE IN THIS AREA

DO NOT WRITE IN THIS AREA



DO NOT WRITE IN THIS AREA

DO NOT WRITE IN THIS AREA

DO NOT WRITE IN THIS AREA

4 A student investigated the vibration of a metal wire using the apparatus shown.

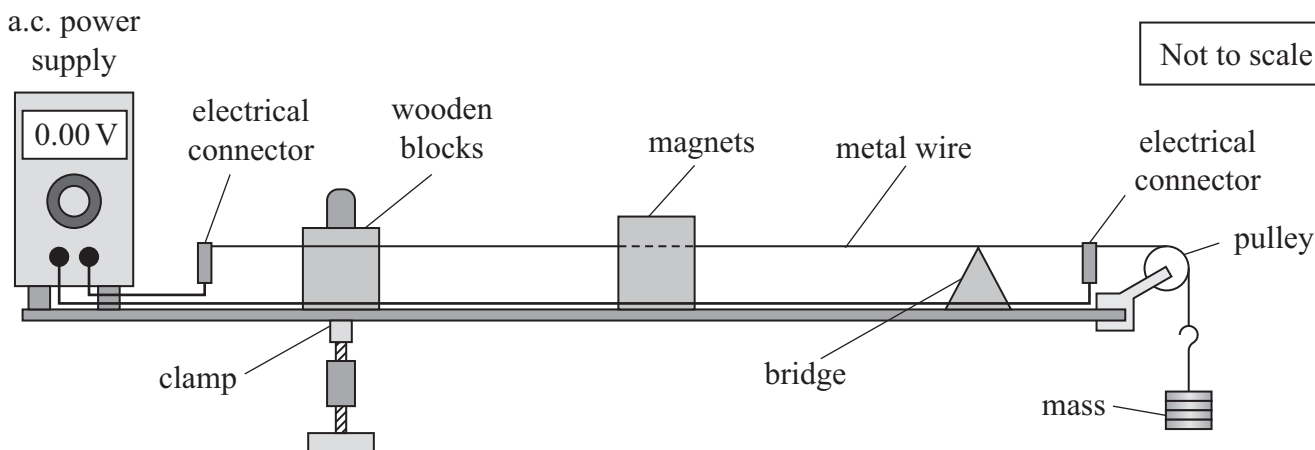

The student switched on the power supply and the metal wire vibrated with a small amplitude.

- (a) Moving the bridge changes the amplitude of the vibration. There is a maximum amplitude when the bridge is a distance L from the wooden blocks.

Describe an accurate method to determine the value of L .

(4)

.....

.....

.....

.....

.....

.....

.....

.....

.....

.....

- (b) The student used a micrometer screw gauge to measure the diameter d of the wire.

Explain one technique he should use to determine an accurate value for d .

(2)

.....

.....

.....

.....

.....

(c) The relationship between the distance L and the mass M hanging from the wire is

$$L^2 = \frac{Mg}{\pi\rho d^2 f^2}$$

where ρ is the density of the metal and f is the frequency of the power supply.

The student used a frequency meter to measure f .

(i) Show that the value of ρ is about 8100 kg m^{-3} .

$$M = 802 \text{ g}$$

$$d = 1.02 \text{ mm} \pm 0.02 \text{ mm}$$

$$f = 50.3 \text{ Hz}$$

$$L = 0.343 \text{ m} \pm 0.003 \text{ m}$$

(2)

(ii) The frequency meter had a resolution of 0.1 Hz . The uncertainty in the mass is negligible.

Show that the percentage uncertainty in ρ is about 6% .

(4)



(iii) A textbook states that stainless steel has a density of 7800 kg m^{-3} .

Deduce whether the wire could be made from stainless steel.

(2)

(Total for Question 4 = 14 marks)

TOTAL FOR PAPER = 50 MARKS

DO NOT WRITE IN THIS AREA

DO NOT WRITE IN THIS AREA

DO NOT WRITE IN THIS AREA



List of data, formulae and relationships

Acceleration of free fall	$g = 9.81 \text{ m s}^{-2}$	(close to Earth's surface)
Boltzmann constant	$k = 1.38 \times 10^{-23} \text{ J K}^{-1}$	
Coulomb's law constant	$k = 1/4\pi\epsilon_0$ $= 8.99 \times 10^9 \text{ N m}^2 \text{ C}^{-2}$	
Electron charge	$e = -1.60 \times 10^{-19} \text{ C}$	
Electron mass	$m_e = 9.11 \times 10^{-31} \text{ kg}$	
Electronvolt	$1 \text{ eV} = 1.60 \times 10^{-19} \text{ J}$	
Gravitational constant	$G = 6.67 \times 10^{-11} \text{ N m}^2 \text{ kg}^{-2}$	
Gravitational field strength	$g = 9.81 \text{ N kg}^{-1}$	(close to Earth's surface)
Permittivity of free space	$\epsilon_0 = 8.85 \times 10^{-12} \text{ F m}^{-1}$	
Planck constant	$h = 6.63 \times 10^{-34} \text{ J s}$	
Proton mass	$m_p = 1.67 \times 10^{-27} \text{ kg}$	
Speed of light in a vacuum	$c = 3.00 \times 10^8 \text{ m s}^{-1}$	
Stefan-Boltzmann constant	$\sigma = 5.67 \times 10^{-8} \text{ W m}^{-2} \text{ K}^{-4}$	
Unified atomic mass unit	$u = 1.66 \times 10^{-27} \text{ kg}$	

Unit 1

Mechanics

Kinematic equations of motion

$$s = \frac{(u + v)t}{2}$$

$$v = u + at$$

$$s = ut + \frac{1}{2}at^2$$

$$v^2 = u^2 + 2as$$

Forces

$$\Sigma F = ma$$

$$g = \frac{F}{m}$$

$$W = mg$$

Momentum

$$p = mv$$

Moment of force

$$\text{moment} = Fx$$

Work and energy

$$\Delta W = F\Delta s$$

$$E_k = \frac{1}{2}mv^2$$

$$\Delta E_{\text{grav}} = mg\Delta h$$

Power

$$P = \frac{E}{t}$$

$$P = \frac{W}{t}$$



Efficiency

$$\text{efficiency} = \frac{\text{useful energy output}}{\text{total energy input}}$$

$$\text{efficiency} = \frac{\text{useful power output}}{\text{total power input}}$$

Materials

Density

$$\rho = \frac{m}{V}$$

Stokes' law

$$F = 6\pi\eta rv$$

Hooke's law

$$\Delta F = k\Delta x$$

Elastic strain energy

$$\Delta E_{\text{el}} = \frac{1}{2}F\Delta x$$

Young modulus

$$E = \frac{\sigma}{\varepsilon} \text{ where}$$

$$\text{Stress } \sigma = \frac{F}{A}$$

$$\text{Strain } \varepsilon = \frac{\Delta x}{x}$$

DO NOT WRITE IN THIS AREA

DO NOT WRITE IN THIS AREA

DO NOT WRITE IN THIS AREA



Unit 2*Waves*

Wave speed	$v = f\lambda$
Speed of a transverse wave on a string	$v = \sqrt{\frac{T}{\mu}}$
Intensity of radiation	$I = \frac{P}{A}$
Refractive index	$n_1 \sin \theta_1 = n_2 \sin \theta_2$ $n = \frac{c}{v}$
Critical angle	$\sin C = \frac{1}{n}$
Diffraction grating	$n\lambda = d \sin \theta$

Electricity

Potential difference	$V = \frac{W}{Q}$
Resistance	$R = \frac{V}{I}$
Electrical power, energy	$P = VI$ $P = I^2R$ $P = \frac{V^2}{R}$ $W = VI t$
Resistivity	$R = \frac{\rho l}{A}$
Current	$I = \frac{\Delta Q}{\Delta t}$ $I = nqvA$
Resistors in series	$R = R_1 + R_2 + R_3$
Resistors in parallel	$\frac{1}{R} = \frac{1}{R_1} + \frac{1}{R_2} + \frac{1}{R_3}$

Particle nature of light

Photon model	$E = hf$
Einstein's photoelectric equation	$hf = \phi + \frac{1}{2}mv_{\max}^2$
de Broglie wavelength	$\lambda = \frac{h}{p}$



Unit 4

Further mechanics

Impulse

$$F\Delta t = \Delta p$$

Kinetic energy of a non-relativistic particle

$$E_k = \frac{p^2}{2m}$$

Motion in a circle

$$v = \omega r$$

$$T = \frac{2\pi}{\omega}$$

$$a = \frac{v^2}{r}$$

$$a = r\omega^2$$

Centripetal force

$$F = ma = \frac{mv^2}{r}$$

$$F = mr\omega^2$$

Electric and magnetic fields

Electric field

$$E = \frac{F}{Q}$$

Coulomb's law

$$F = \frac{Q_1 Q_2}{4\pi\epsilon_0 r^2}$$

$$E = \frac{Q}{4\pi\epsilon_0 r^2}$$

$$E = \frac{V}{d}$$

Electrical potential

$$V = \frac{Q}{4\pi\epsilon_0 r}$$

Capacitance

$$C = \frac{Q}{V}$$

Energy stored in capacitor

$$W = \frac{1}{2} QV$$

$$W = \frac{1}{2} CV^2$$

$$W = \frac{1}{2} \frac{Q^2}{C}$$

Capacitor discharge

$$Q = Q_0 e^{-t/RC}$$

DO NOT WRITE IN THIS AREA

DO NOT WRITE IN THIS AREA

DO NOT WRITE IN THIS AREA



Resistor-capacitor discharge

$$I = I_0 e^{-t/RC}$$

$$V = V_0 e^{-t/RC}$$

$$\ln Q = \ln Q_0 - \frac{t}{RC}$$

$$\ln I = \ln I_0 - \frac{t}{RC}$$

$$\ln V = \ln V_0 - \frac{t}{RC}$$

In a magnetic field

$$F = Bqv \sin \theta$$

$$F = BIl \sin \theta$$

Faraday's and Lenz's laws

$$\mathcal{E} = \frac{-d(N\phi)}{dt}$$

Nuclear and particle physics

In a magnetic field

$$r = \frac{p}{BQ}$$

Mass-energy

$$\Delta E = c^2 \Delta m$$

DO NOT WRITE IN THIS AREA

DO NOT WRITE IN THIS AREA

DO NOT WRITE IN THIS AREA



Unit 5*Thermodynamics*

Heating $\Delta E = mc\Delta\theta$

$$\Delta E = L\Delta m$$

Ideal gas equation $pV = NkT$

Molecular kinetic theory $\frac{1}{2} m \langle c^2 \rangle = \frac{3}{2} kT$

Nuclear decay

Mass-energy $\Delta E = c^2 \Delta m$

Radioactive decay $A = \lambda N$

$$\frac{dN}{dt} = -\lambda N$$

$$\lambda = \frac{\ln 2}{t_{1/2}}$$

$$N = N_0 e^{-\lambda t}$$

$$A = A_0 e^{-\lambda t}$$

Oscillations

Simple harmonic motion $F = -kx$

$$a = -\omega^2 x$$

$$x = A \cos \omega t$$

$$v = -A\omega \sin \omega t$$

$$a = -A\omega^2 \cos \omega t$$

$$T = \frac{1}{f} = \frac{2\pi}{\omega}$$

$$\omega = 2\pi f$$

Simple harmonic oscillator

$$T = 2\pi \sqrt{\frac{m}{k}}$$

$$T = 2\pi \sqrt{\frac{l}{g}}$$



Astrophysics and cosmology

Gravitational field strength $g = \frac{F}{m}$

Gravitational force $F = \frac{Gm_1m_2}{r^2}$

Gravitational field $g = \frac{Gm}{r^2}$

Gravitational potential $V_{\text{grav}} = \frac{-Gm}{r}$

Stefan-Boltzmann law $L = \sigma AT^4$

Wien's law $\lambda_{\text{max}}T = 2.898 \times 10^{-3} \text{ mK}$

Intensity of radiation $I = \frac{L}{4\pi d^2}$

Redshift of electromagnetic radiation $z = \frac{\Delta\lambda}{\lambda} \approx \frac{\Delta f}{f} \approx \frac{v}{c}$

Cosmological expansion $v = H_0 d$

DO NOT WRITE IN THIS AREA

DO NOT WRITE IN THIS AREA

DO NOT WRITE IN THIS AREA



DO NOT WRITE IN THIS AREA

DO NOT WRITE IN THIS AREA

DO NOT WRITE IN THIS AREA

BLANK PAGE



P 7 9 1 4 8 A 0 2 3 2 4

DO NOT WRITE IN THIS AREA

DO NOT WRITE IN THIS AREA

DO NOT WRITE IN THIS AREA

BLANK PAGE

