

Please check the examination details below before entering your candidate information

Candidate surname

Other names

Centre Number

Candidate Number

**Pearson Edexcel International Advanced Level**

**Tuesday 21 October 2025**

Morning (Time: 1 hour 45 minutes)

Paper  
reference

**WPH14/01**

**Physics**

**International Advanced Level**

**UNIT 4: Further Mechanics, Fields and Particles**

**You must have:**

Scientific calculator

Total Marks

### Instructions

- Use **black** ink or ball-point pen.
- If pencil is used for diagrams/sketches/graphs it must be dark (HB or B).
- **Fill in the boxes** at the top of this page with your name, centre number and candidate number.
- Answer **all** questions.
- Answer the questions in the spaces provided  
– *there may be more space than you need.*
- **Show all your working out** in calculations and **include units** where appropriate.

### Information

- The total mark for this paper is 90.
- The marks for **each** question are shown in brackets  
– *use this as a guide as to how much time to spend on each question.*
- In the question marked with an **asterisk** (\*), marks will be awarded for your ability to structure your answer logically, showing how the points that you make are related or follow on from each other where appropriate.
- The list of data, formulae and relationships is printed at the end of this booklet.

### Advice

- Read each question carefully before you start to answer it.
- Try to answer every question.
- Check your answers if you have time at the end.

Turn over ►

P78834A

©2025 Pearson Education Ltd.  
M:1/1/1/1/



  
Pearson

## SECTION A

Answer ALL questions.

For questions 1–10, in Section A, select one answer from A to D and put a cross in the box . If you change your mind, put a line through the box  and then mark your new answer with a cross .

1 Which of the following shows the electric field around a proton?

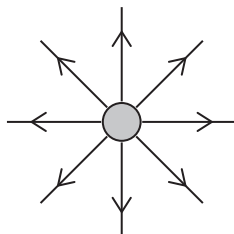

A

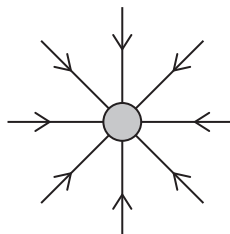

B

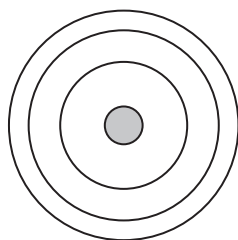

C

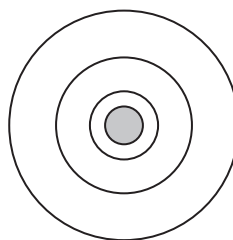

D

- A
- B
- C
- D

(Total for Question 1 = 1 mark)

2 In the Sun, two protons can combine to form a proton, a neutron and another particle X, as shown.

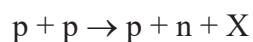

Which of the following particles could be X?

- A a negatively charged baryon
- B a negatively charged meson
- C a positively charged baryon
- D a positively charged meson

(Total for Question 2 = 1 mark)



3 An alpha particle passes through a small thickness of absorber. The momentum of the alpha particle is halved.

The initial kinetic energy of the alpha particle is  $E$ .

Which of the following is the kinetic energy of the alpha particle after passing through the absorber?

A  $\frac{E}{2}$

B  $\frac{E}{4}$

C  $\frac{E}{8}$

D  $\frac{E}{16}$

(Total for Question 3 = 1 mark)

4 Which of the following is a scalar quantity?

A capacitance

B centripetal acceleration

C impulse

D momentum

(Total for Question 4 = 1 mark)

5 Muons are unstable particles. At speeds approaching the speed of light, relativistic effects change the lifetime and the rate of decay of the muons.

Which row of the table is correct for these muons?

	Lifetime of muons	Rate of decay of muons
<input type="checkbox"/> A	decreases	decreases
<input type="checkbox"/> B	decreases	increases
<input type="checkbox"/> C	increases	decreases
<input type="checkbox"/> D	increases	increases

(Total for Question 5 = 1 mark)



6 Two circuits, J and K, each contain a coil.

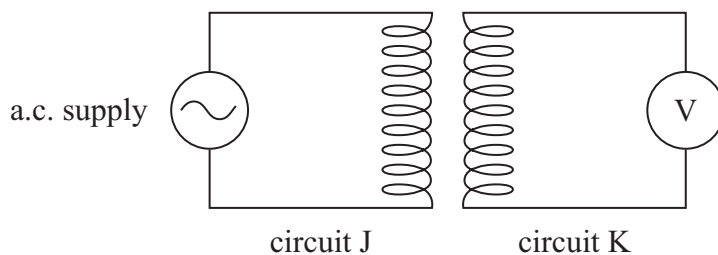

When the a.c. supply is switched on, an e.m.f. is induced across the coil in circuit K.

Which of the following would increase the magnitude of the induced e.m.f.?

- A increasing the distance between the coils
- B increasing the frequency of the a.c. supply
- C decreasing the number of turns in the coil in circuit K
- D decreasing the magnitude of the potential difference of the a.c. supply

(Total for Question 6 = 1 mark)

7 A nucleus of  ${}_{6}^{11}\text{C}$  decays by releasing a positron  $e^{+}$ .

Which row of the table shows the proton number and nucleon number of the nucleus produced?

	Proton number	Nucleon number
<input type="checkbox"/> A	5	11
<input type="checkbox"/> B	5	12
<input type="checkbox"/> C	7	11
<input type="checkbox"/> D	7	12

(Total for Question 7 = 1 mark)



- 8 In a cyclotron, charged particles are accelerated to high speeds by applying an alternating potential difference (p.d.) between two 'dees'.

The alternating p.d. must have a particular frequency for the particles to be accelerated each time they cross between the 'dees'.

Which of the following statements is **not** correct?

- A The frequency depends on the charge of the particle.
- B The frequency depends on the mass of the particle.
- C The frequency depends on the magnetic flux density.
- D The frequency depends on the velocity of the particle.

(Total for Question 8 = 1 mark)

- 9 A ball of mass  $m$  falls to the ground and rebounds, as shown.

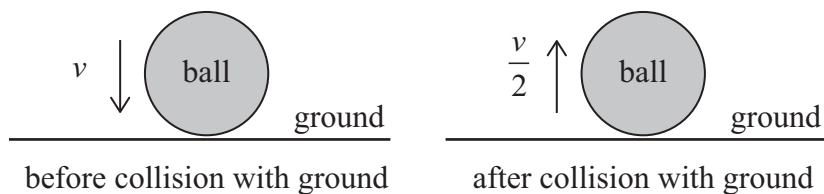

The speed of the ball just before colliding with the ground is  $v$ .

The speed of the ball as it rebounds from the ground is  $\frac{v}{2}$ .

The time taken for the collision is  $\Delta t$ .

Which row of the table is correct for the mean force  $F$  acting on the ground during the collision?

	Magnitude of $F$	Direction of $F$
<input type="checkbox"/> A	$\frac{mv}{2\Delta t}$	downwards
<input type="checkbox"/> B	$\frac{mv}{2\Delta t}$	upwards
<input type="checkbox"/> C	$\frac{3mv}{2\Delta t}$	downwards
<input type="checkbox"/> D	$\frac{3mv}{2\Delta t}$	upwards

(Total for Question 9 = 1 mark)



10 A particle moves at constant speed in a circle.

P and Q are two positions of the particle.

The velocity at P is  $v_P$  and the velocity at Q is  $v_Q$ , as shown.

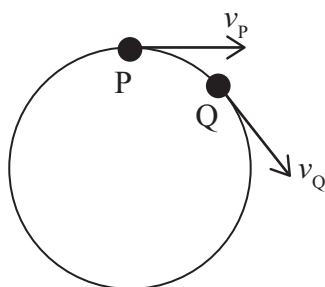

As the particle moves from P to Q, the change in velocity is  $\Delta v$ .

Which of the following is a correct vector diagram for the change in velocity of the particle?

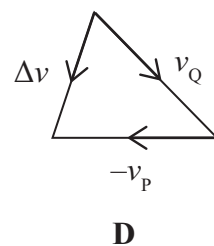
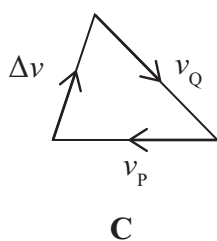
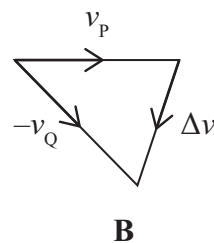
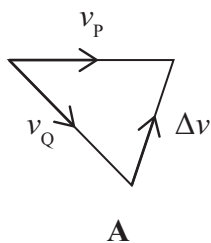

- A
- B
- C
- D

(Total for Question 10 = 1 mark)

TOTAL FOR SECTION A = 10 MARKS



**SECTION B**

**Answer ALL questions in the spaces provided.**

**11** A nucleus of zinc has a charge of  $4.8 \times 10^{-18}$  C. The nucleus is placed in a vacuum.

Calculate the electric field strength at a distance  $1.3 \times 10^{-10}$  m from the zinc nucleus.

.....

.....

.....

Electric field strength = .....

**(Total for Question 11 = 2 marks)**

DO NOT WRITE IN THIS AREA

DO NOT WRITE IN THIS AREA

DO NOT WRITE IN THIS AREA



12 A capacitor of capacitance  $47 \mu\text{F} \pm 20\%$  was connected to a 400 V supply.

Calculate the maximum energy that could be stored in the capacitor.

.....

.....

.....

.....

.....

Maximum energy = .....

**(Total for Question 12 = 3 marks)**

DO NOT WRITE IN THIS AREA

DO NOT WRITE IN THIS AREA

DO NOT WRITE IN THIS AREA



DO NOT WRITE IN THIS AREA

DO NOT WRITE IN THIS AREA

DO NOT WRITE IN THIS AREA

13 In 1928, one of the first linacs was built and used to accelerate heavy ions.

The ions reached the end of the linac with energy 1.25 MeV and speed  $1.10 \times 10^6 \text{ ms}^{-1}$ .

The table shows some heavy ions and their masses.

Heavy ion	Mass / kg
tungsten	$3.05 \times 10^{-25}$
mercury	$3.33 \times 10^{-25}$
lead	$3.44 \times 10^{-25}$

Deduce which heavy ion was used in this linac.

.....

.....

.....

.....

.....

.....

(Total for Question 13 = 3 marks)



14 During a flight, an aeroplane was moving through the magnetic field of the Earth.

- (a) At one point during the flight, the magnetic field of the Earth was at an angle of  $65^\circ$  to the horizontal, as shown.

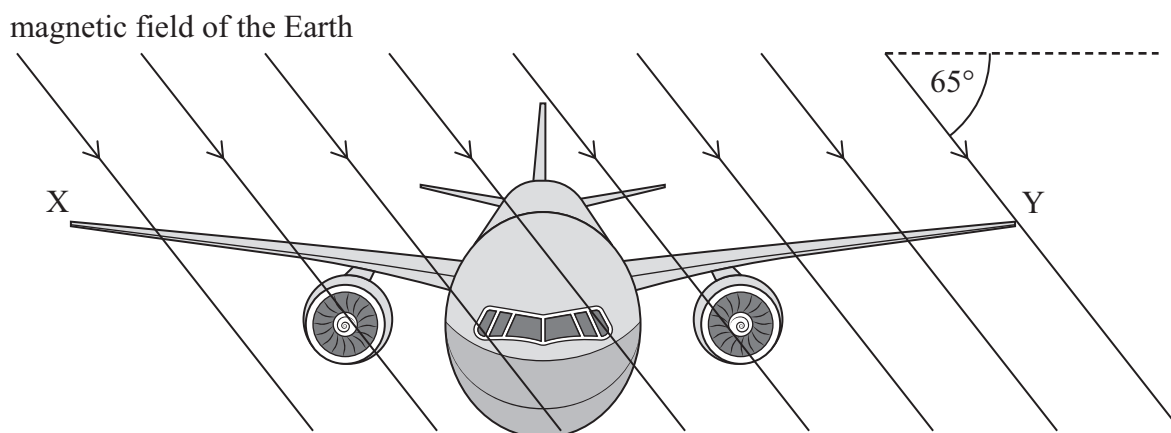

- (i) The magnetic field of the Earth had a flux density of  $5.5 \times 10^{-5} \text{ T}$ .

Show that the vertical component of the magnetic flux density was about  $5.0 \times 10^{-5} \text{ T}$ .

(1)

- (ii) The distance XY across the wingtips was 68.4 m.

The aeroplane was flying at a speed of  $256 \text{ m s}^{-1}$ .

Determine the e.m.f. induced across the wingtips.

(3)

e.m.f. = .....



DO NOT WRITE IN THIS AREA

DO NOT WRITE IN THIS AREA

DO NOT WRITE IN THIS AREA

(b) The shape of the magnetic field of the Earth is shown below.

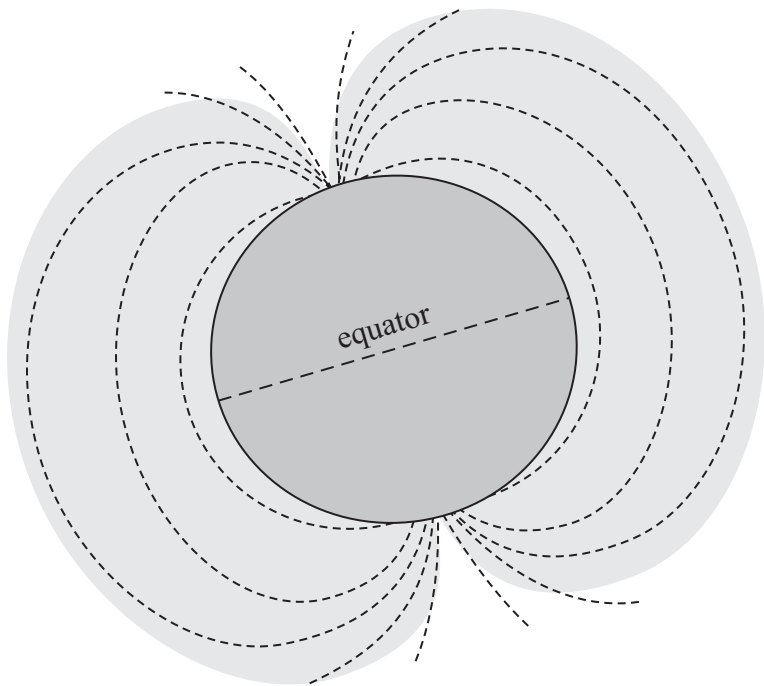

An aeroplane was flying at constant height along the equator.

Explain why the e.m.f. induced across the wingtips of the aeroplane is zero.

(2)

.....

.....

.....

.....

.....

.....

.....

**(Total for Question 14 = 6 marks)**



15 In 2022, scientists using the Large Hadron Collider reported the discovery of two new ‘tetraquarks’.

A tetraquark consists of two quarks and two antiquarks.

(a) Some scientists have suggested that a tetraquark is a combination of two mesons.

State the structure of a meson.

(1)

(b) One of the tetraquarks had a charge of  $+2e$ .

This tetraquark consists of a combination of up, down, strange and charm quarks or antiquarks.

The table shows the charge on each quark.

Quark	Charge / e
up	$+\frac{2}{3}$
down	$-\frac{1}{3}$
strange	$-\frac{1}{3}$
charm	$+\frac{2}{3}$

Determine a possible combination of quarks and antiquarks in this tetraquark.

(1)





16 A student had a bucket containing some water. He swung the bucket in a vertical circle, as shown. The water stayed in the bucket.

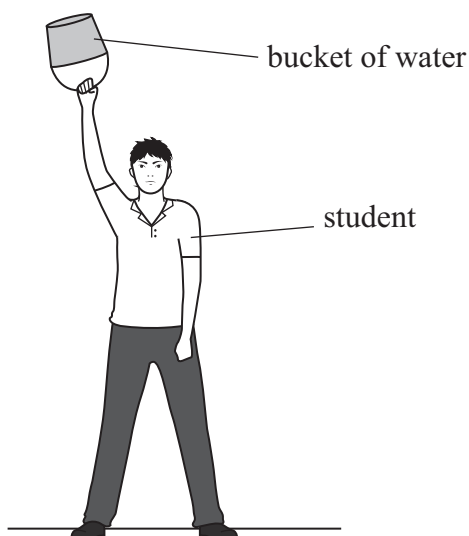

(a) State the two forces acting on the water in the bucket.

(2)

.....

.....

.....

.....

(b) The water will stay in the bucket at the top of the vertical circle if the speed of the bucket is large enough.

Explain why there is a minimum speed for the water to stay in the bucket.

(3)

.....

.....

.....

.....

.....

.....

.....

.....

.....

(Total for Question 16 = 5 marks)



DO NOT WRITE IN THIS AREA

DO NOT WRITE IN THIS AREA

DO NOT WRITE IN THIS AREA

**BLANK PAGE**



P 7 8 8 3 4 A 0 1 5 3 6

- 17 In some countries there is ice and snow in winter. The photograph shows a child sitting inside a 'snow tube', sliding on ice.

The friction between the snow tube and the ice is negligible.



(Source: © Cavan Images/Alamy Stock Photo)

Two children were in snow tubes. Child A was travelling at  $2.38 \text{ m s}^{-1}$ . Child B was stationary. The two snow tubes collided.

After the collision, child A travelled at  $1.36 \text{ m s}^{-1}$  at an angle of  $33^\circ$  to the original direction.

Child B travelled with a velocity  $v$  at an angle  $\theta$  to the original direction, as shown.

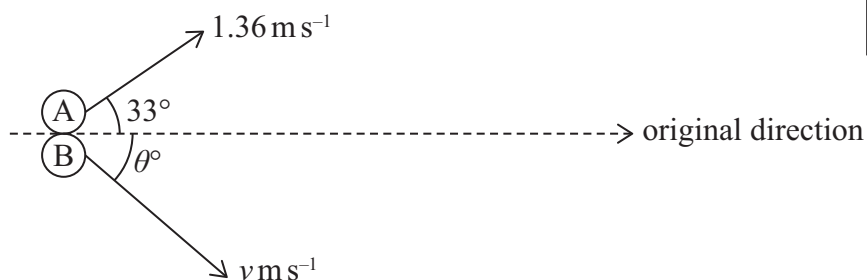

mass of child A = 45 kg

mass of child B = 30 kg



DO NOT WRITE IN THIS AREA

DO NOT WRITE IN THIS AREA

DO NOT WRITE IN THIS AREA

(a) Show that the angle  $\theta$  was about  $31^\circ$ .

(4)

.....

.....

.....

.....

.....

.....

.....

.....

.....

.....

.....

.....

.....

.....

.....

.....

.....

.....

.....

.....

.....

.....

.....

(b) Deduce whether the collision was elastic.

(4)

.....

.....

.....

.....

.....

.....

.....

.....

.....

.....

.....

.....

.....

.....

.....

.....

.....

.....

.....

.....

.....

.....

.....

**(Total for Question 17 = 8 marks)**



18 The photograph shows particle tracks in a bubble chamber. The uniform magnetic field in the bubble chamber is perpendicular to the page.

The tracks show the decay of a pion plus ( $\pi^+$ ). The  $\pi^+$  was formed at Y and decayed at Z.

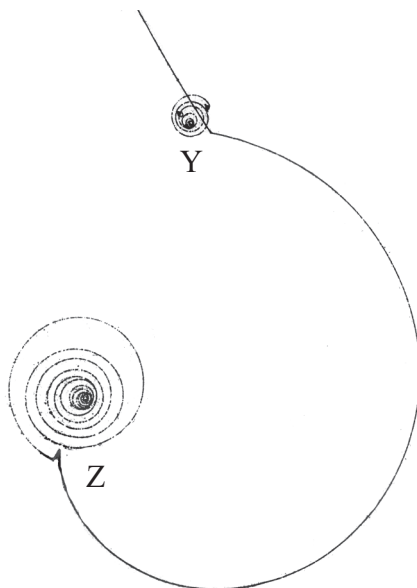

(Source: © GORONWY TUDOR JONES, UNIVERSITY OF BIRMINGHAM/SCIENCE PHOTO LIBRARY)

(a) Explain how the magnetic field affects the path of the  $\pi^+$ . (3)

.....

.....

.....

.....

.....

.....





19 In large angle alpha particle scattering experiments, alpha particles were directed towards a thin gold foil in an evacuated chamber.

\*(a) A simplified diagram of the original apparatus used in these experiments is shown.

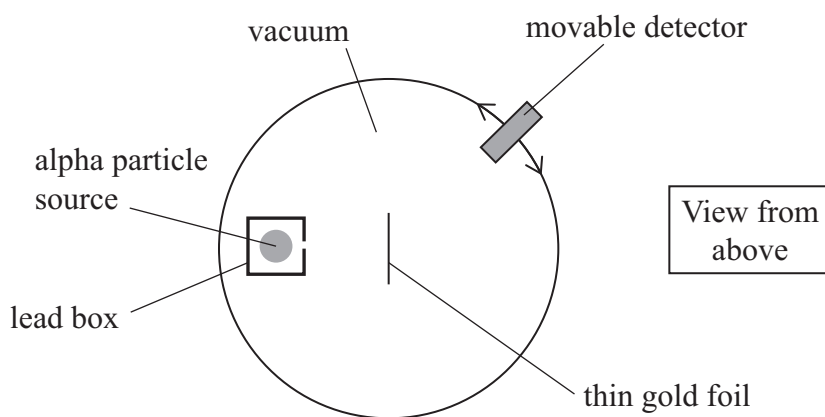

These experiments resulted in a new model of the atom.

Describe the evidence and conclusions made from these experiments.

(6)

.....

.....

.....

.....

.....

.....

.....

.....

.....

.....

.....

.....

.....

.....

.....

.....

.....

.....

.....

.....

.....

.....



DO NOT WRITE IN THIS AREA

(b) An alpha particle moves towards a gold (Au) nucleus head-on, as shown.

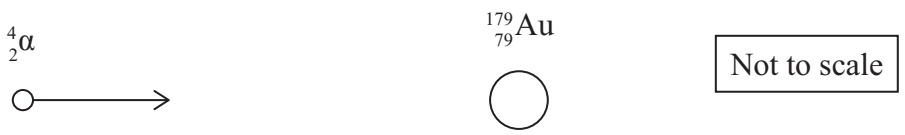

The alpha particle decelerates as it moves towards the gold nucleus. The alpha particle is briefly brought to rest before travelling back along its original path.

The alpha particle has a kinetic energy of  $8.5 \times 10^{-13}$  J.

(i) Show that the minimum distance between the alpha particle and the gold nucleus is about  $4 \times 10^{-14}$  m.

(3)

.....

.....

.....

.....

.....

.....

(ii) Calculate the maximum force between the alpha particle and the gold nucleus.

(2)

.....

.....

.....

.....

Maximum force = .....

**(Total for Question 19 = 11 marks)**



20 Most mobile phones have a touchscreen. The screen is connected to an array of capacitors inside the phone. When a finger touches the screen, the capacitance of part of the array changes.

In the array, one capacitor has a capacitance of  $22\ \mu\text{F}$ .

The capacitor charges and discharges through a resistor of resistance  $1200\ \Omega$ .

(a) (i) The potential difference across this capacitor was  $6.0\ \text{V}$ .

Show that the charge on this capacitor was about  $1.3 \times 10^{-4}\ \text{C}$ .

(2)

.....

.....

.....

.....

(ii) For the touchscreen to be sensitive, the capacitor should discharge to 25% of its initial charge within 50 ms.

Deduce whether the touchscreen will be sensitive.

(3)

.....

.....

.....

.....

.....

.....

.....



DO NOT WRITE IN THIS AREA

DO NOT WRITE IN THIS AREA

DO NOT WRITE IN THIS AREA

(b) Sketch on the axes below how the current varies with time as the capacitor discharges.

You should include the value of the maximum current.

(2)

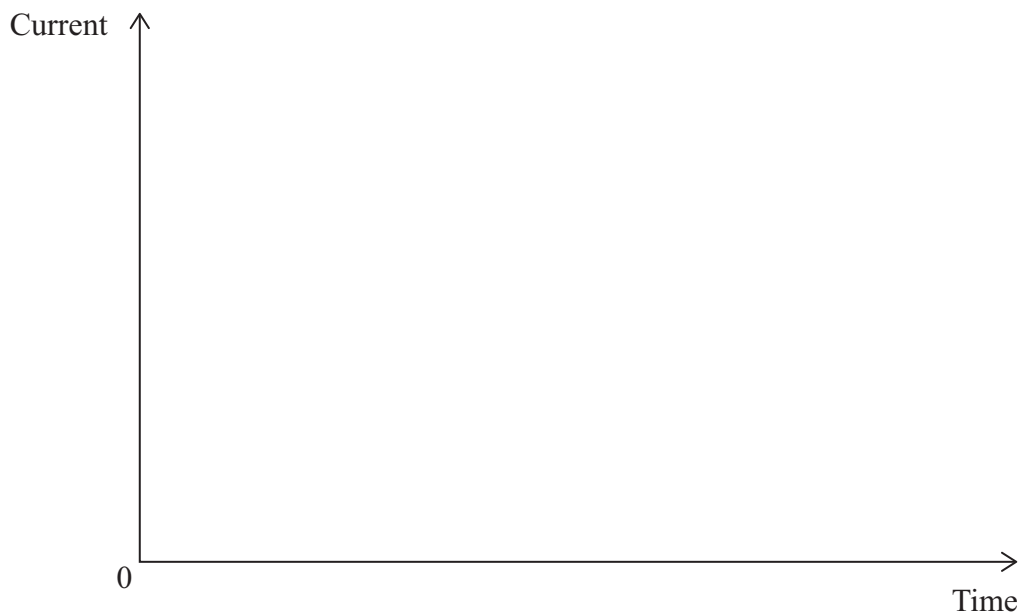

(Total for Question 20 = 7 marks)



P 7 8 8 3 4 A 0 2 3 3 6

21 A simple diagram of an oscilloscope is shown.

Electrons are released from a heated filament. The electrons are accelerated towards the anode and travel as a beam towards the screen.

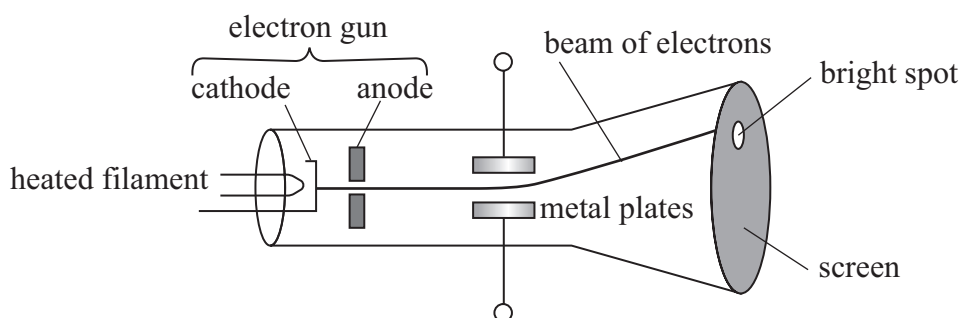

(a) State the process that causes the electrons to be released from the filament.

(1)

(b) A potential difference (p.d.) is applied across the metal plates to create an electric field between them.

The electric field between the metal plates causes an electric force on the electrons.

(i) The p.d. across the metal plates is 120 V. The electric field strength between the metal plates is  $15\,000\text{ V m}^{-1}$ .

Calculate the distance between the metal plates.

(2)

Distance = .....



- (ii) The electric field between the metal plates causes the electrons to accelerate with a constant vertical acceleration.

Show that the vertical acceleration is about  $2.6 \times 10^{15} \text{ ms}^{-2}$ .

(3)

- (iii) The beam of electrons produces a bright spot on the screen.

A student measures the vertical displacement of the bright spot on the screen to be 3.4 cm from its undisplaced position.

An electron in the beam takes  $1.2 \times 10^{-9} \text{ s}$  to travel between the metal plates. The electron takes  $6.9 \times 10^{-9} \text{ s}$  to travel from the end of the metal plates to the screen.

Deduce whether an acceleration of  $2.6 \times 10^{15} \text{ ms}^{-2}$  would produce a vertical displacement of 3.4 cm.

(5)

(Total for Question 21 = 11 marks)

DO NOT WRITE IN THIS AREA

DO NOT WRITE IN THIS AREA

DO NOT WRITE IN THIS AREA



P 7 8 8 3 4 A 0 2 5 3 6

- 22 A cylindrical copper rod, PQ, is placed on a pair of copper rails. The rails are connected to a battery and a switch. The rod and rails are in a uniform magnetic field which is directed into the page, as shown.

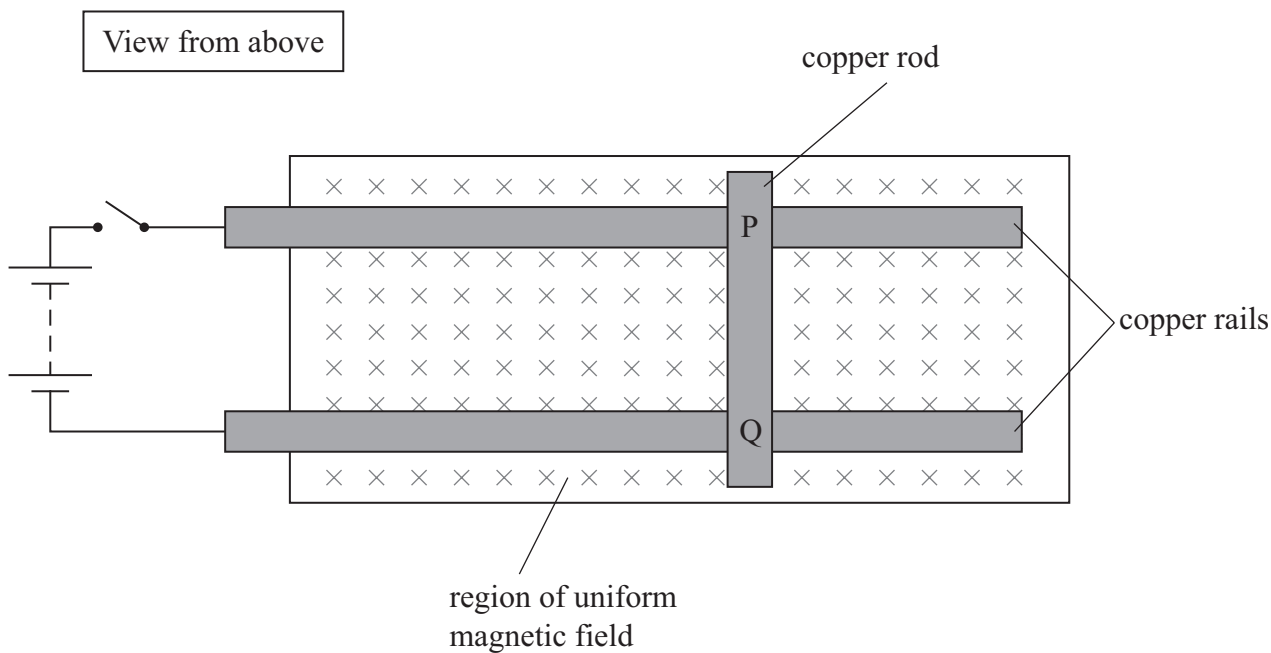

- (a) When the switch is closed, a force acts on the rod and it begins to move along the rails.

Explain which direction the rod moves along the rails.

(2)

.....

.....

.....

.....

DO NOT WRITE IN THIS AREA

DO NOT WRITE IN THIS AREA

DO NOT WRITE IN THIS AREA



DO NOT WRITE IN THIS AREA

DO NOT WRITE IN THIS AREA

DO NOT WRITE IN THIS AREA

(b) The rod accelerates uniformly from rest along the rails.

After the rod has travelled  $6.5 \times 10^{-2}$  m, it has a speed of  $3.5 \times 10^{-2} \text{ m s}^{-1}$ .

Calculate the magnetic flux density of the magnetic field.

length of rod between rails =  $7.5 \times 10^{-2}$  m

mass of rod =  $1.5 \times 10^{-2}$  kg

current in rod = 0.32 A

(4)

.....

.....

.....

.....

.....

.....

.....

.....

Magnetic flux density = .....





### List of data, formulae and relationships

Acceleration of free fall	$g = 9.81 \text{ m s}^{-2}$	(close to Earth's surface)
Boltzmann constant	$k = 1.38 \times 10^{-23} \text{ J K}^{-1}$	
Coulomb's law constant	$k = 1/4\pi\epsilon_0$ $= 8.99 \times 10^9 \text{ N m}^2 \text{ C}^{-2}$	
Electron charge	$e = -1.60 \times 10^{-19} \text{ C}$	
Electron mass	$m_e = 9.11 \times 10^{-31} \text{ kg}$	
Electronvolt	$1 \text{ eV} = 1.60 \times 10^{-19} \text{ J}$	
Gravitational constant	$G = 6.67 \times 10^{-11} \text{ N m}^2 \text{ kg}^{-2}$	
Gravitational field strength	$g = 9.81 \text{ N kg}^{-1}$	(close to Earth's surface)
Permittivity of free space	$\epsilon_0 = 8.85 \times 10^{-12} \text{ F m}^{-1}$	
Planck constant	$h = 6.63 \times 10^{-34} \text{ J s}$	
Proton mass	$m_p = 1.67 \times 10^{-27} \text{ kg}$	
Speed of light in a vacuum	$c = 3.00 \times 10^8 \text{ m s}^{-1}$	
Stefan-Boltzmann constant	$\sigma = 5.67 \times 10^{-8} \text{ W m}^{-2} \text{ K}^{-4}$	
Unified atomic mass unit	$u = 1.66 \times 10^{-27} \text{ kg}$	

#### Unit 1

##### Mechanics

Kinematic equations of motion	$s = \frac{(u + v)t}{2}$
	$v = u + at$
	$s = ut + \frac{1}{2}at^2$
	$v^2 = u^2 + 2as$

Forces	$\Sigma F = ma$
	$g = \frac{F}{m}$
	$W = mg$

Momentum	$p = mv$
----------	----------

Moment of force	moment = $Fx$
-----------------	---------------

Work and energy	$\Delta W = F\Delta s$
	$E_k = \frac{1}{2}mv^2$
	$\Delta E_{\text{grav}} = mg\Delta h$

Power	$P = \frac{E}{t}$
	$P = \frac{W}{t}$



Efficiency

$$\text{efficiency} = \frac{\text{useful energy output}}{\text{total energy input}}$$

$$\text{efficiency} = \frac{\text{useful power output}}{\text{total power input}}$$

*Materials*

Density

$$\rho = \frac{m}{V}$$

Stokes' law

$$F = 6\pi\eta rv$$

Hooke's law

$$\Delta F = k\Delta x$$

Elastic strain energy

$$\Delta E_{\text{el}} = \frac{1}{2}F\Delta x$$

Young modulus

$$E = \frac{\sigma}{\varepsilon} \text{ where}$$

$$\text{Stress } \sigma = \frac{F}{A}$$

$$\text{Strain } \varepsilon = \frac{\Delta x}{x}$$

DO NOT WRITE IN THIS AREA

DO NOT WRITE IN THIS AREA

DO NOT WRITE IN THIS AREA



**Unit 2***Waves*

Wave speed

$$v = f\lambda$$

Speed of a transverse wave on a string

$$v = \sqrt{\frac{T}{\mu}}$$

Intensity of radiation

$$I = \frac{P}{A}$$

Refractive index

$$n_1 \sin \theta_1 = n_2 \sin \theta_2$$

$$n = \frac{c}{v}$$

Critical angle

$$\sin C = \frac{1}{n}$$

Diffraction grating

$$n\lambda = d \sin \theta$$

*Electricity*

Potential difference

$$V = \frac{W}{Q}$$

Resistance

$$R = \frac{V}{I}$$

Electrical power, energy

$$P = VI$$

$$P = I^2R$$

$$P = \frac{V^2}{R}$$

$$W = VI t$$

Resistivity

$$R = \frac{\rho l}{A}$$

Current

$$I = \frac{\Delta Q}{\Delta t}$$

$$I = nqvA$$

Resistors in series

$$R = R_1 + R_2 + R_3$$

Resistors in parallel

$$\frac{1}{R} = \frac{1}{R_1} + \frac{1}{R_2} + \frac{1}{R_3}$$

*Particle nature of light*

Photon model

$$E = hf$$

Einstein's photoelectric equation

$$hf = \phi + \frac{1}{2}mv_{\max}^2$$

de Broglie wavelength

$$\lambda = \frac{h}{p}$$



**Unit 4***Further mechanics*

Impulse

$$F\Delta t = \Delta p$$

Kinetic energy of a non-relativistic particle

$$E_k = \frac{p^2}{2m}$$

Motion in a circle

$$v = \omega r$$

$$T = \frac{2\pi}{\omega}$$

$$a = \frac{v^2}{r}$$

$$a = r\omega^2$$

Centripetal force

$$F = ma = \frac{mv^2}{r}$$

$$F = mr\omega^2$$

*Electric and magnetic fields*

Electric field

$$E = \frac{F}{Q}$$

Coulomb's law

$$F = \frac{Q_1 Q_2}{4\pi\epsilon_0 r^2}$$

$$E = \frac{Q}{4\pi\epsilon_0 r^2}$$

$$E = \frac{V}{d}$$

Electrical potential

$$V = \frac{Q}{4\pi\epsilon_0 r}$$

Capacitance

$$C = \frac{Q}{V}$$

Energy stored in capacitor

$$W = \frac{1}{2} QV$$

$$W = \frac{1}{2} CV^2$$

$$W = \frac{1}{2} \frac{Q^2}{C}$$

Capacitor discharge

$$Q = Q_0 e^{-t/RC}$$



Resistor-capacitor discharge

$$I = I_0 e^{-t/RC}$$

$$V = V_0 e^{-t/RC}$$

$$\ln Q = \ln Q_0 - \frac{t}{RC}$$

$$\ln I = \ln I_0 - \frac{t}{RC}$$

$$\ln V = \ln V_0 - \frac{t}{RC}$$

In a magnetic field

$$F = Bqv \sin \theta$$

$$F = BIl \sin \theta$$

Faraday's and Lenz's laws

$$\mathcal{E} = \frac{-d(N\phi)}{dt}$$

*Nuclear and particle physics*

In a magnetic field

$$r = \frac{p}{BQ}$$

Mass-energy

$$\Delta E = c^2 \Delta m$$

DO NOT WRITE IN THIS AREA

DO NOT WRITE IN THIS AREA

DO NOT WRITE IN THIS AREA



DO NOT WRITE IN THIS AREA

DO NOT WRITE IN THIS AREA

DO NOT WRITE IN THIS AREA

**BLANK PAGE**



DO NOT WRITE IN THIS AREA

DO NOT WRITE IN THIS AREA

DO NOT WRITE IN THIS AREA

**BLANK PAGE**



P 7 8 8 3 4 A 0 3 5 3 6

DO NOT WRITE IN THIS AREA

DO NOT WRITE IN THIS AREA

DO NOT WRITE IN THIS AREA

**BLANK PAGE**

